



Mike Muller

CTO ARM

Unlocking New Semiconductor Opportunities in Connectivity



Node	45nm	22nm	11nm
Year	2008	2014	2020
Area ⁻¹	1	4	16
Peak freq	1	1.6	2.4
Power	1	1	0.6

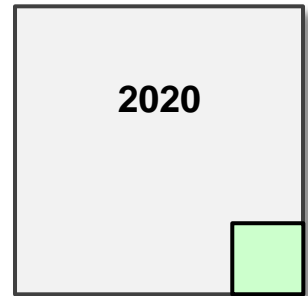
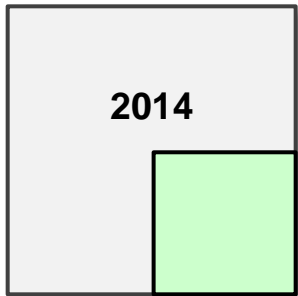
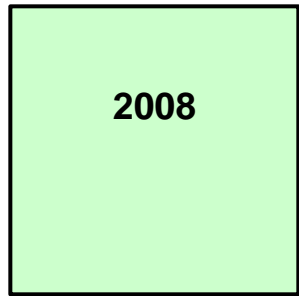

$(4 \times 1)^{-1} = 25\%$

$(16 \times 0.6)^{-1} = 10\%$

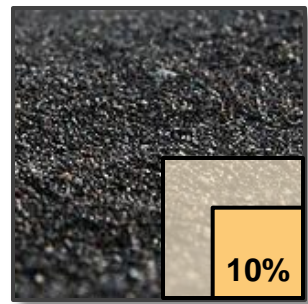
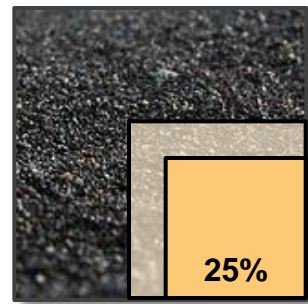
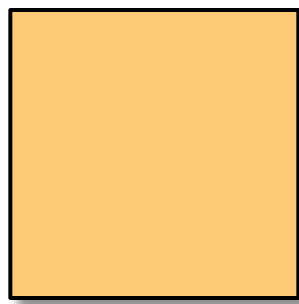

Exploitable Si
(in 45nm power budget)

Source: ITRS 2008

Up in the Clouds



The cloud will define the **software** platform
The client will be a server

Servers?

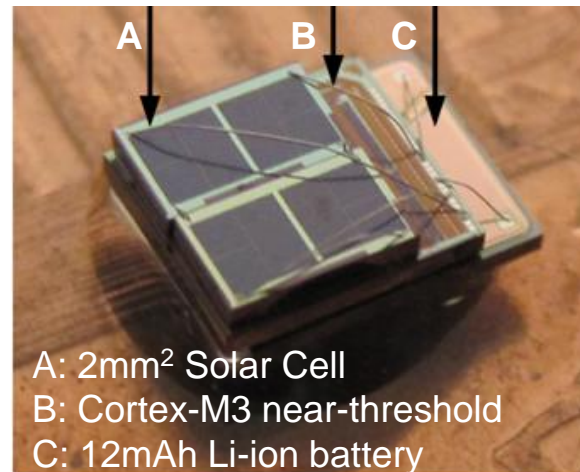
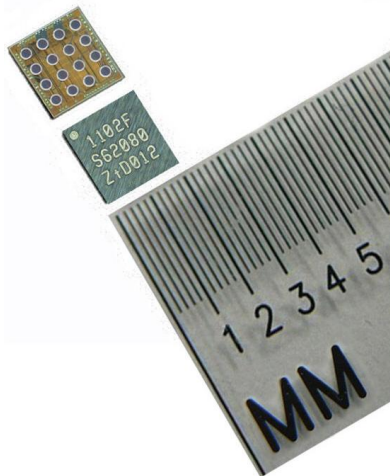
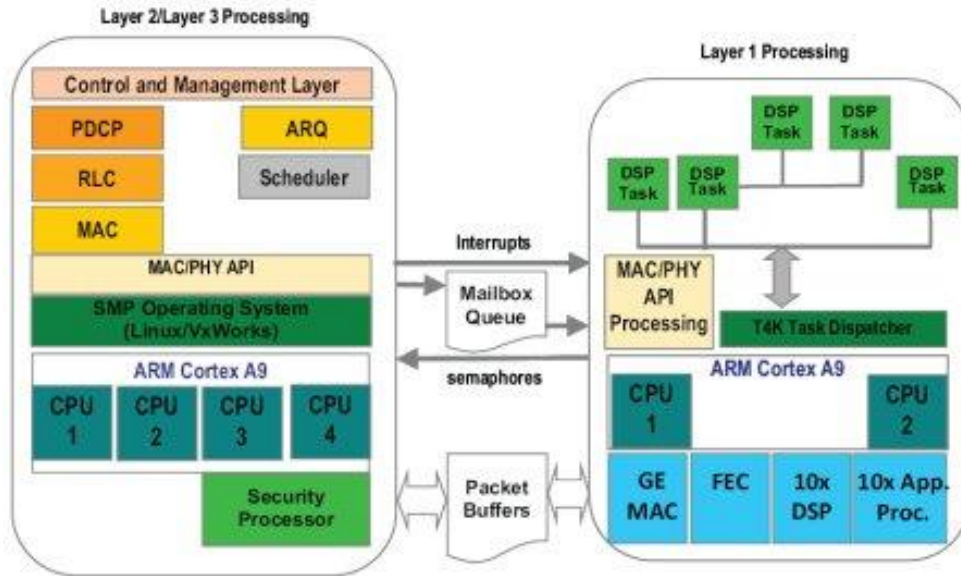

3rd Era of Computing – Consumerisation

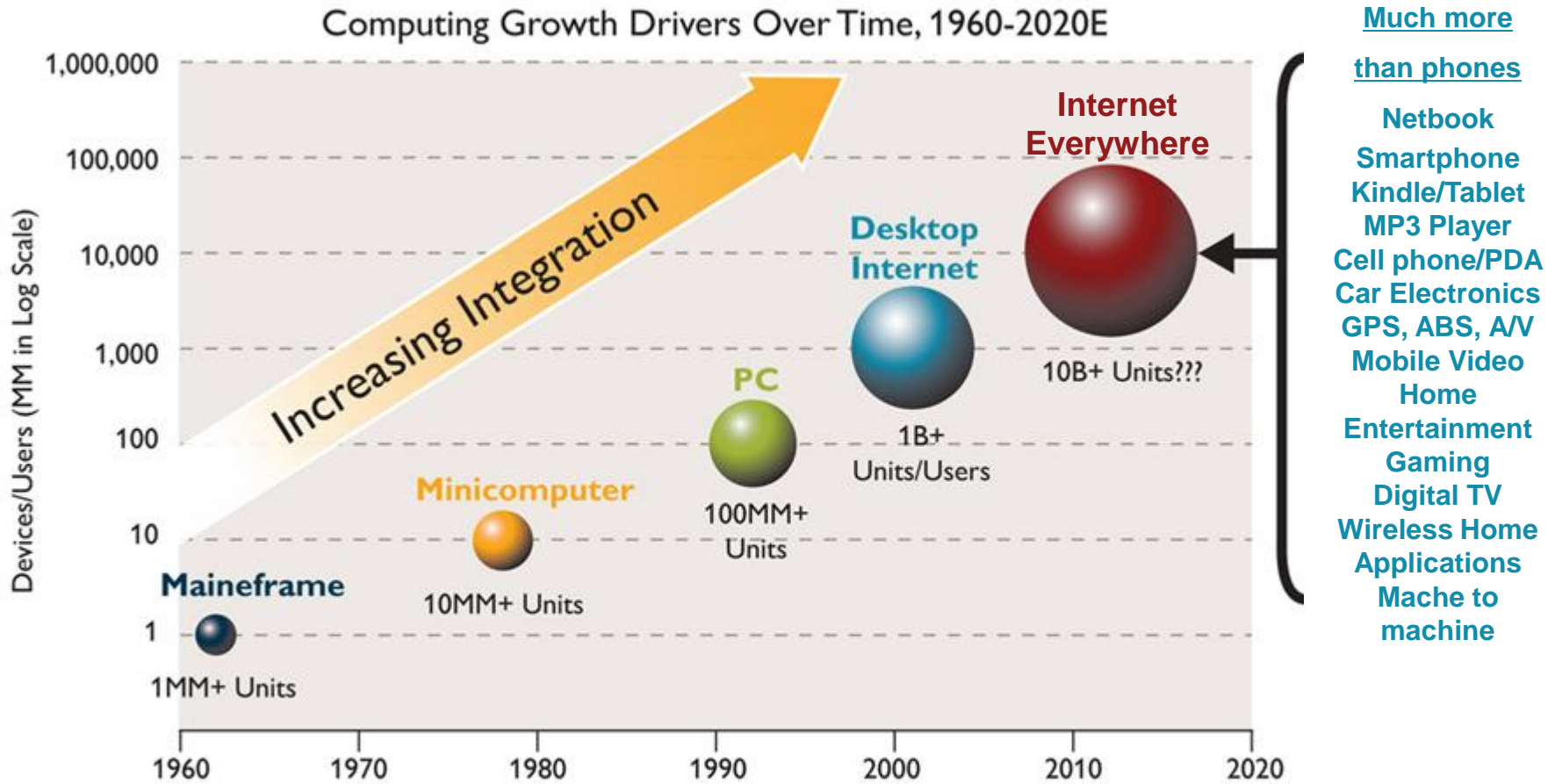

Note: PC installed base reached 100MM in 1993, cellphone/internet users reached 1B in 2002/2005 respectively.
Source: ITU, Mark Lipcis, Morgan Stanley Research